

Maths.scot



National 5 Maths

Pythagoras in a Circle

SQA past paper and specimen paper
questions and answers by topic

SQA material is copyright © Scottish Qualifications Authority
and has been reproduced by kind permission of SQA.

This resource is free to distribute and use on a non-commercial basis.

Visit [Maths.scot](https://www.maths.scot) for full worked solutions to each of these questions.



The diagram below shows a circle, centre C.

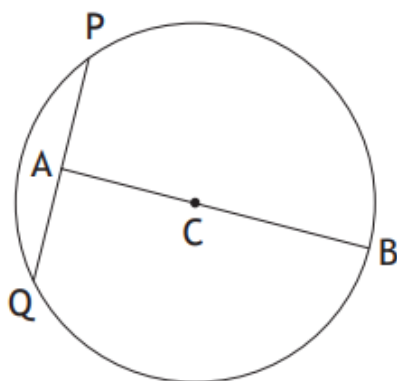

The radius of the circle is 15 centimetres.

A is the mid-point of chord PQ.

The length of AB is 27 centimetres.

Calculate the length of PQ.

4

Answer:

18 cm

The diagram below shows the circular cross-section of a milk tank.

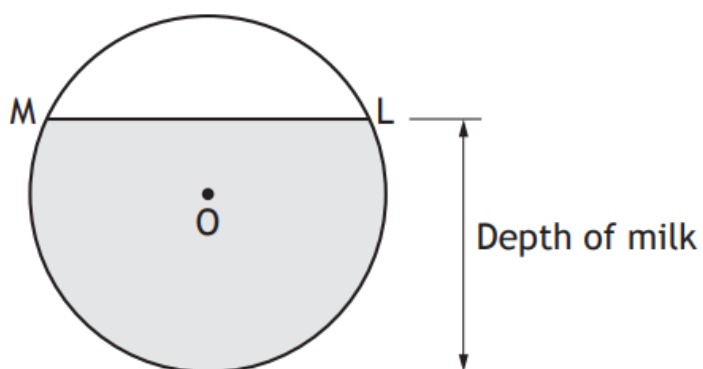

The radius of the circle, centre O , is 1.2 metres.

The width of the surface of the milk in the tank, represented by ML in the diagram, is 1.8 metres.

Calculate the depth of the milk in the tank.

4

Answer:

1.99 m

This perfume bottle has a label in the shape of part of a circle.

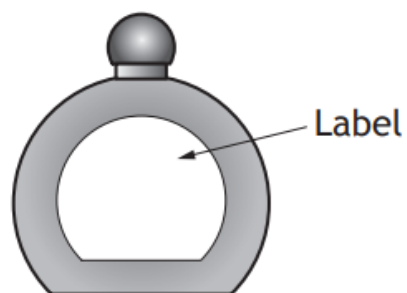

A diagram of the label is shown below.

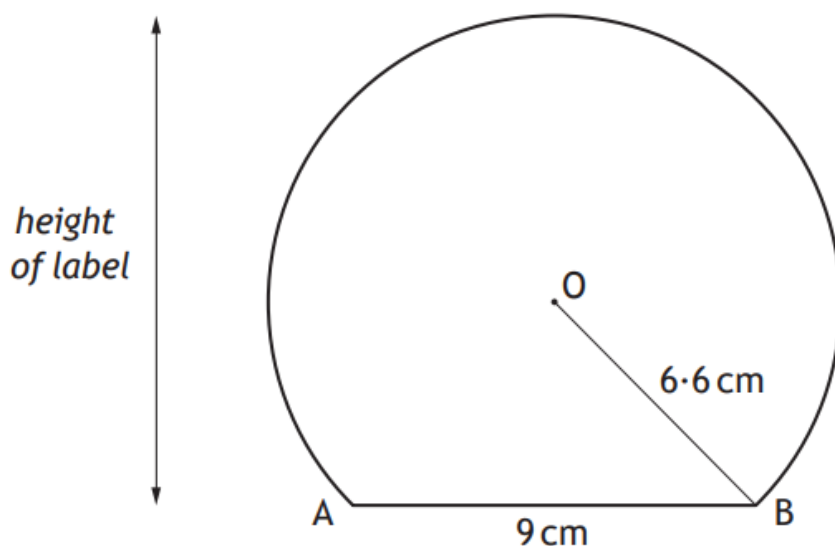

- The centre of the circle is O.
- The chord AB is 9 centimetres.
- The radius OB is 6.6 centimetres.

Find the height of the label.

4

Answer:

11.4 cm

A cylindrical pipe has water in it as shown.

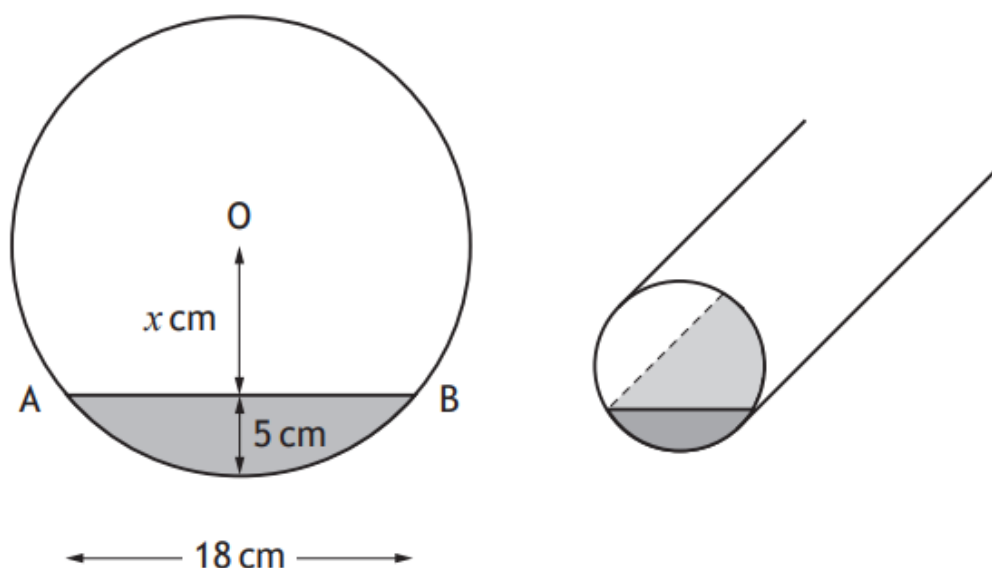

The depth of the water at the deepest point is 5 centimetres.

The width of the water surface, AB, is 18 centimetres.

The radius of the pipe is r centimetres.

The distance from the centre, O, of the pipe to the water surface is x centimetres.

- (a) Write down an expression for x in terms of r . 1
- (b) Calculate r , the radius of the pipe. 3

Answers:

- (a) $x = r - 5$
- (b) 10.6 cm

Two identical shapes are used to form a logo.
Each shape is part of a circle.

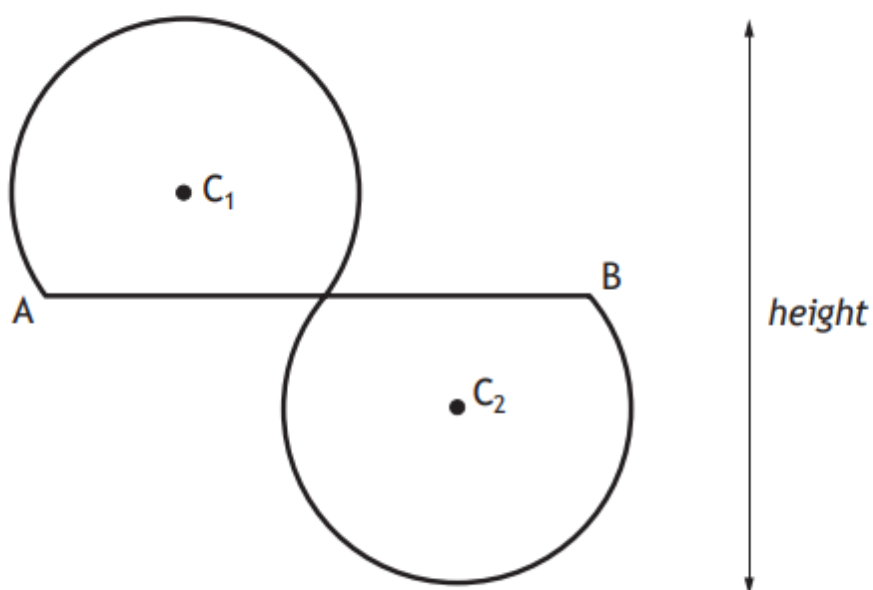

- The circles have centres C_1 and C_2 .
- The radius of each circle is 14 centimetres.
- The logo has half-turn symmetry about the mid-point of AB .
- AB is 48 centimetres long.

Calculate the height of the logo.

4

Answer:

42.4 cm

The shape below is part of a circle, centre O.

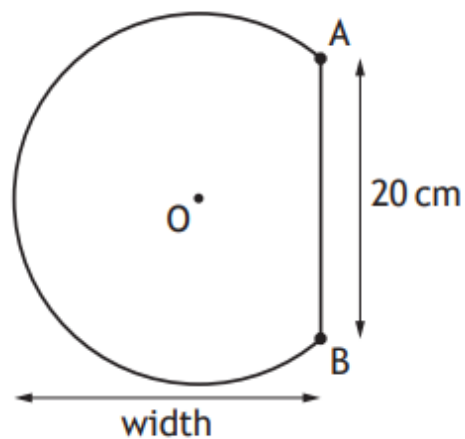

The circle has radius 13 centimetres.

AB is a chord of length 20 centimetres.

Calculate the width of the shape.

4

Answer:

21.3 cm

The picture shows a cartoon snowman.



The diagram below represents the snowman.

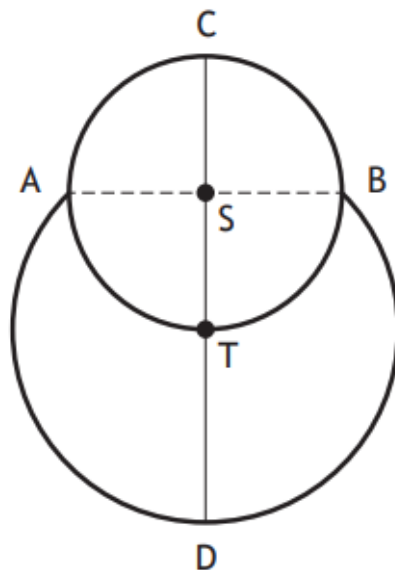

- The head is a small circle, centre S , with diameter 15 centimetres
- The body is part of a larger circle, centre T
- The point T lies on the circumference of the small circle
- The points A and B lie on the circumferences of both circles

Calculate CD , the height of the snowman.

4

Answer: 25.6 cm

The diagram below shows a design for a memory stick.

The design consists of a rectangle, RSTU and part of a circle, centre C.

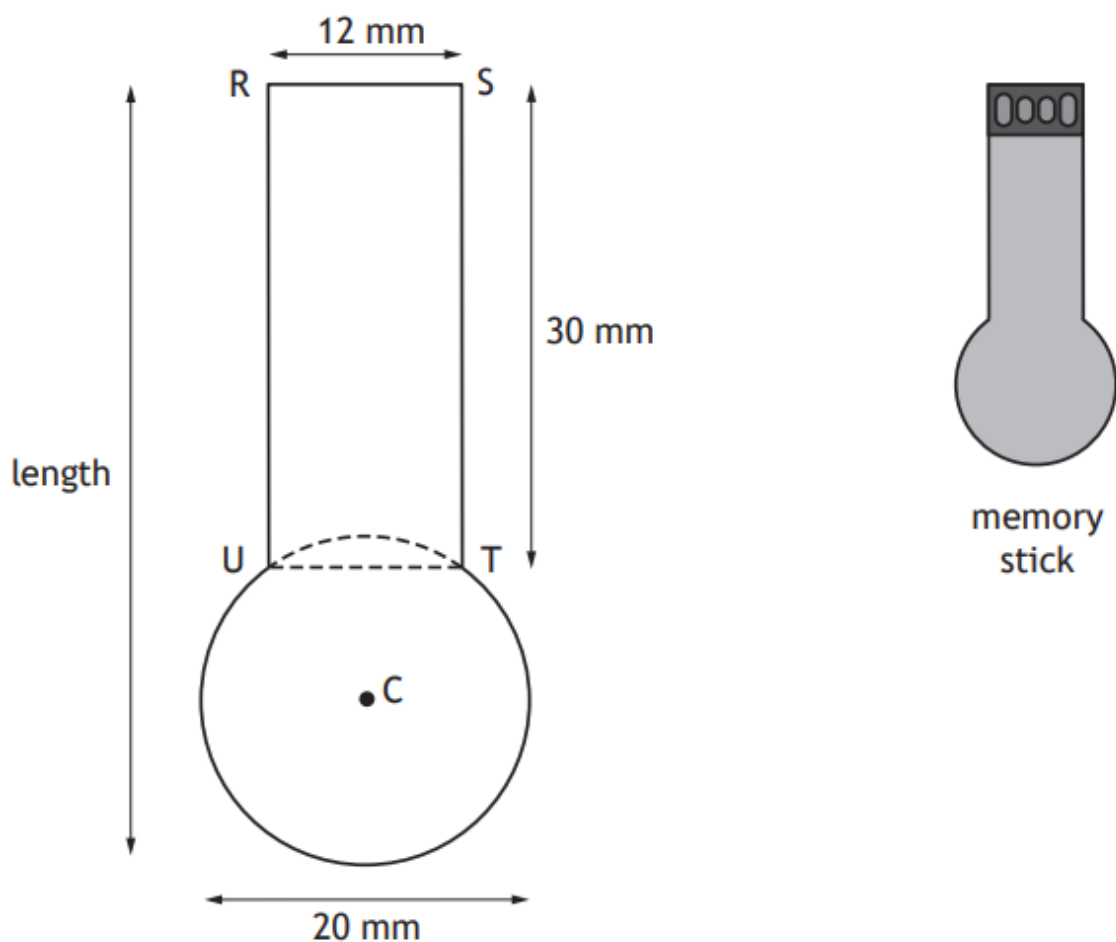

- $RS = UT = 12$ millimetres
- $RU = ST = 30$ millimetres
- The diameter of the circle is 20 millimetres
- UT is a chord of the circle

Calculate the length of the memory stick.

4

Answer: 48 mm

A train tunnel has a circular cross-section with a horizontal floor.

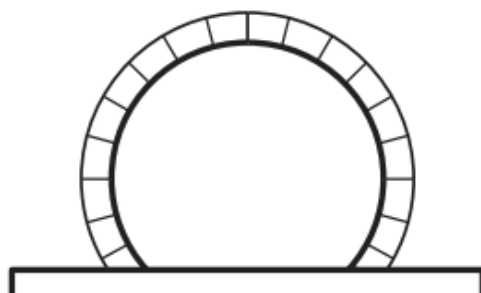

A diagram of the cross-section is shown below.

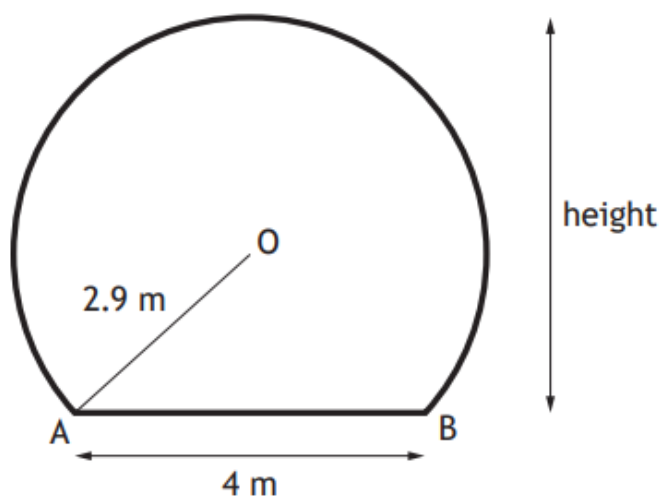

- The centre of the circle is O.
- Chord AB is 4 metres.
- The radius OA is 2.9 metres.

Calculate the height of the tunnel.

4

Answer:

5 m

Alan buys some identical paving slabs to make a path.
Each slab is part of a circle.

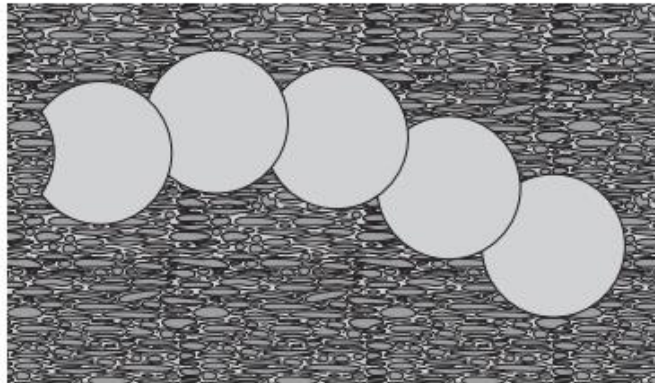

The diagram below shows a single slab.

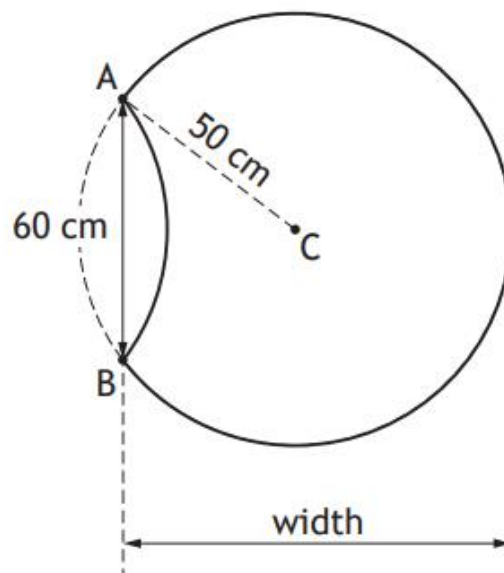

The circle, centre C, has a radius of 50 centimetres.
Length AB is 60 centimetres.
Calculate the width of the paving slab.

4

Answer: 90 cm