



National 5 Maths Sine Rule

SQA past paper and specimen paper
questions and answers by topic

SQA material is copyright © Scottish Qualifications Authority
and has been reproduced by kind permission of SQA.

This resource is free to distribute and use on a non-commercial basis.

Visit [Maths.scot](https://www.maths.scot) for full worked solutions to each of these questions.



National 5 Maths
SQA 2014 Paper 1
Question 5

National 5 Maths

Maths.scot



In triangle KLM

- $KM = 18$ centimetres
- $\sin K = 0.4$
- $\sin L = 0.9$

Calculate the length of LM.

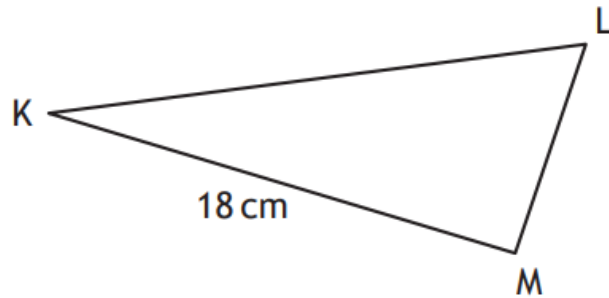

3

Answer:

8 cm

National 5 Maths
SQA 2015 Paper 2
Question 13

National 5 Maths

Maths.scot



In the diagram below P, Q and R represent the positions of Portlee, Queenstown and Rushton respectively.

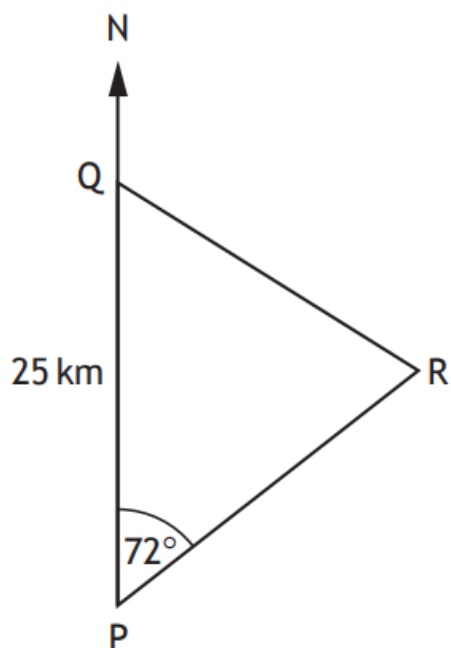

Portlee is 25 kilometres due South of Queenstown.

From Portlee, the bearing of Rushton is 072° .

From Queenstown, the bearing of Rushton is 128° .

Calculate the distance between Portlee and Rushton.

Do not use a scale drawing.

4

Answer:

23.8 km



A set of stepladders has legs 150 centimetres and 140 centimetres long.



When the stepladder is fully open, the angle between the longer leg and the ground is 66° .

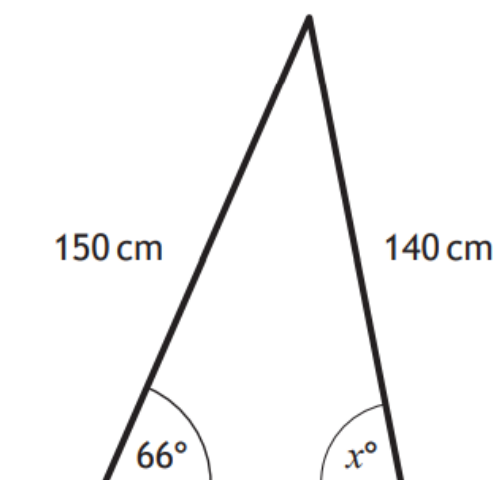

Calculate x° , the size of the angle between the shorter leg and the ground.

3

Answer:

78.2°

The top of a table is in the shape of a regular hexagon.

The three diagonals of the hexagon, which are shown as dotted lines in the diagram below, each have length 40 centimetres.

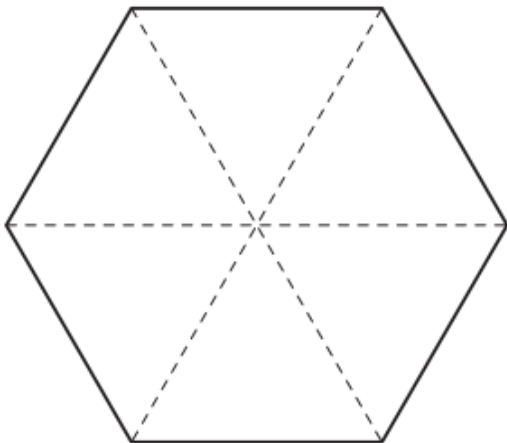

Calculate the area of the top of the table.

4

Answer:

1039.2 cm²



In the diagram below D, E and F represent the positions of Dunbridge, Earlsford and Fairtown respectively.

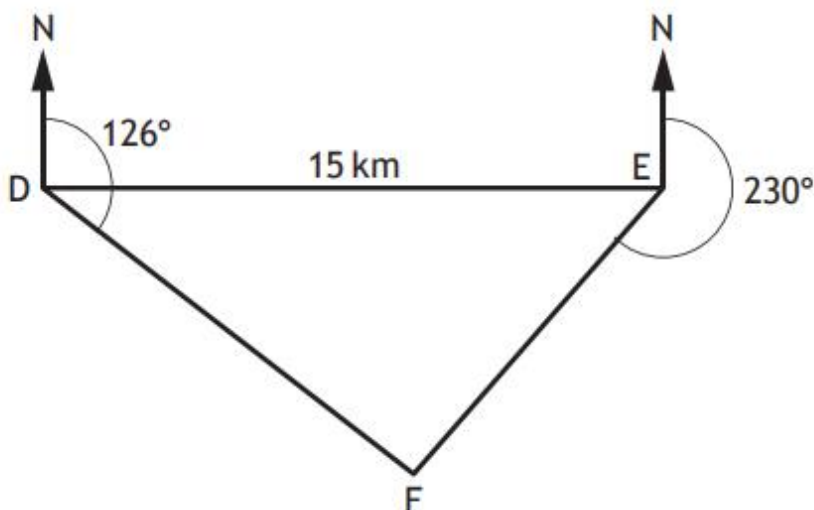

Dunbridge is 15 kilometres west of Earlsford.

From Dunbridge, the bearing of Fairtown is 126° .

From Earlsford the bearing of Fairtown is 230° .

Calculate the distance between Dunbridge and Fairtown.

4

Do not use a scale drawing.

Answer:

9.9 km

National 5 Maths
SQA 2018 Paper 2
Question 9

In this diagram:

- angle $ABD = 75^\circ$
- angle $BDC = 37^\circ$
- $BC = 20$ centimetres.

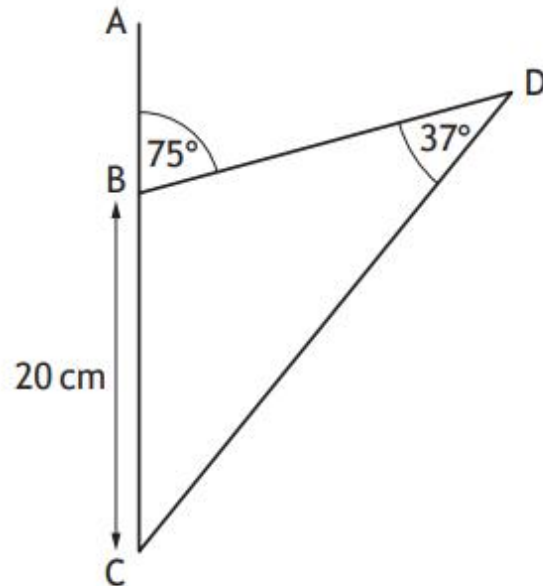

Calculate the length of DC .

3

Answer:

32.1 cm



Katy and Mona are looking up at a hot-air balloon.

In the diagram below, K, M and B represent the positions of Katy, Mona and the balloon respectively.

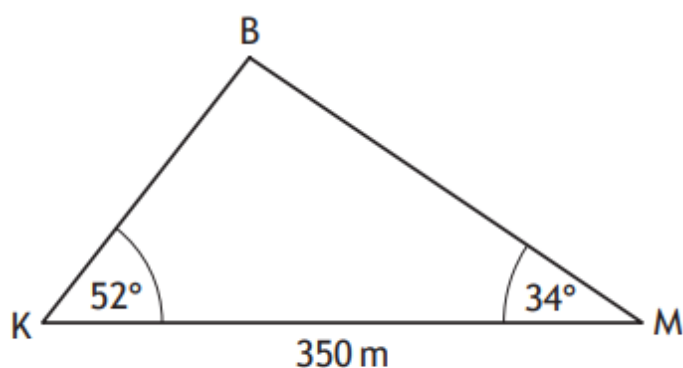

- The angle of elevation of the balloon from Katy is 52°
- The angle of elevation of the balloon from Mona is 34°
- Katy and Mona are 350 metres apart on level ground

Calculate the height of the hot-air balloon above the ground.

5

Answer:

154.6 m

National 5 Maths
SQA 2021 Paper 2
Question 4

National 5 Maths

Maths.scot



In triangle PQR

- $PR = 11.3$ metres
- $QR = 9.8$ metres
- angle $QPR = 54^\circ$.

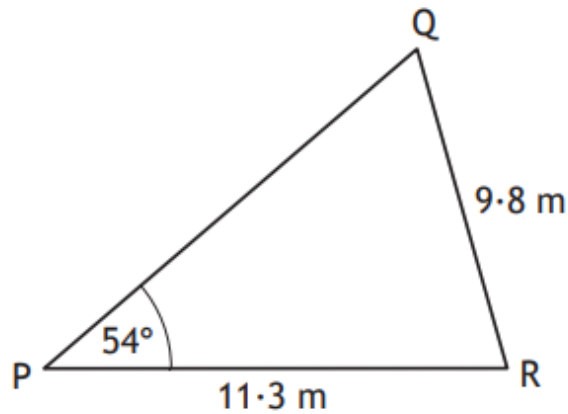

Calculate the size of acute angle PQR.

3

Answer:

68.9°

The width of a river is represented by BC in the diagram below.
AB represents a tree on the river bank.

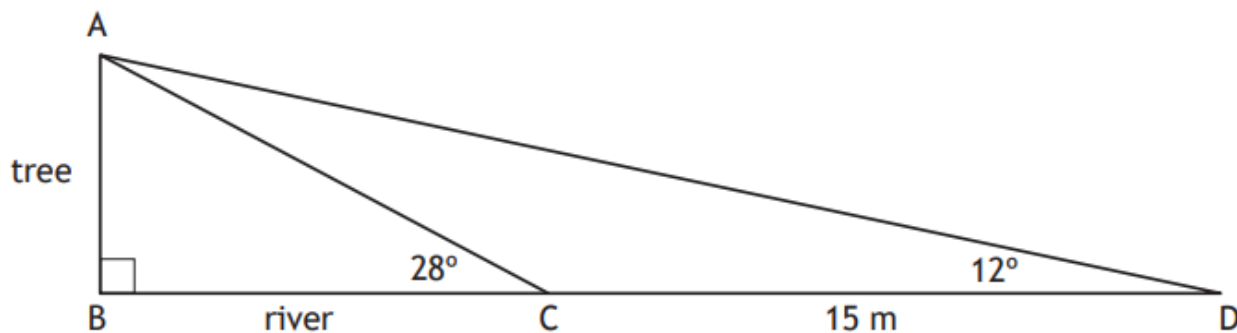

- From C, the angle of elevation to A is 28° .
- From D, the angle of elevation to A is 12° .
- The distance from C to D is 15 metres.
- BCD is a straight line.

Calculate BC, the width of the river.

5

Answer:

9.99 m

The diagram shows triangle JKL.

- Angle KJL = 25°
- JL = 10 metres
- KL = 7 metres

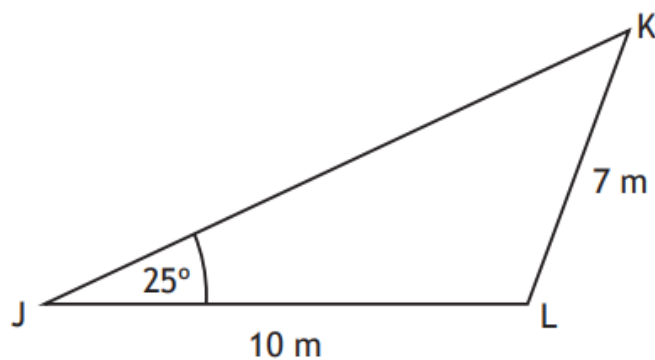

Calculate the size of angle JKL.

3

Answer:

37.1°